



Door Gems

architectural hardware

by

GEORGE RANALLI

YOUR STYLE ISN'T OFF THE RACK. WHY IS YOUR HARDWARE?

Lock-it pictured above is in the 20th Century Collection of the Denver Art Museum

to order: www.georgeranallidesigns.com

DOOR GEMS

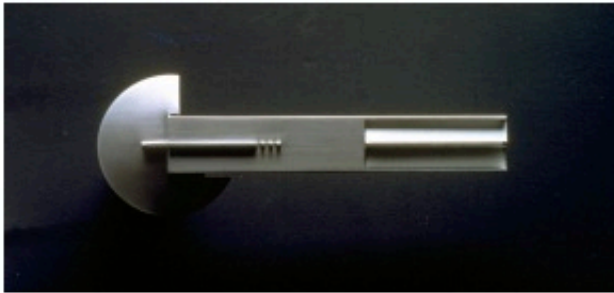

Lock-it

When is a door handle not just a door handle? When it's a Door Gem.

Lock-it designed by architect George Ranalli, and collected by The Denver Art Museum, inaugurates a new line of luxurious door hardware. Door Gems by George Ranalli Designs, a new line of architectural housewares and hardware, riff on geometric form highlighting functionality, materials, and charm. Ranalli's visually stunning Italian Modernist architecture has earned him the appellation of "New York Architect's Architect" by the New York Times. Now, he translates his eye-catching sensibilities to smaller scale design with his signature dramatic intensity.

Originally commissioned by a Japanese manufacturer, Door Gems global birthright is readily apparent. The hardware is startlingly elegant. The Lock-it door lever is more ergonomic than a typical doorknob, and modern design gets a new twist. Ranalli says, "I wanted to design hardware for the beginning of the twenty-first century. It breaks with the current grammar of decoration."

Door Gems, like the perfect piece of jewelry, catches the eye and complements any ensemble. Striking simplicity and exquisite details emphasize the idea of the threshold. Door Gems demarcate spaces of high design. "These designs are the result of an exploration in the relationship between beauty and utility", says Ranalli. "And an introduction to the spaces, colors and forms behind the doors of a beautiful life."

George Ranalli Designs

www.georgeranallidesigns.com



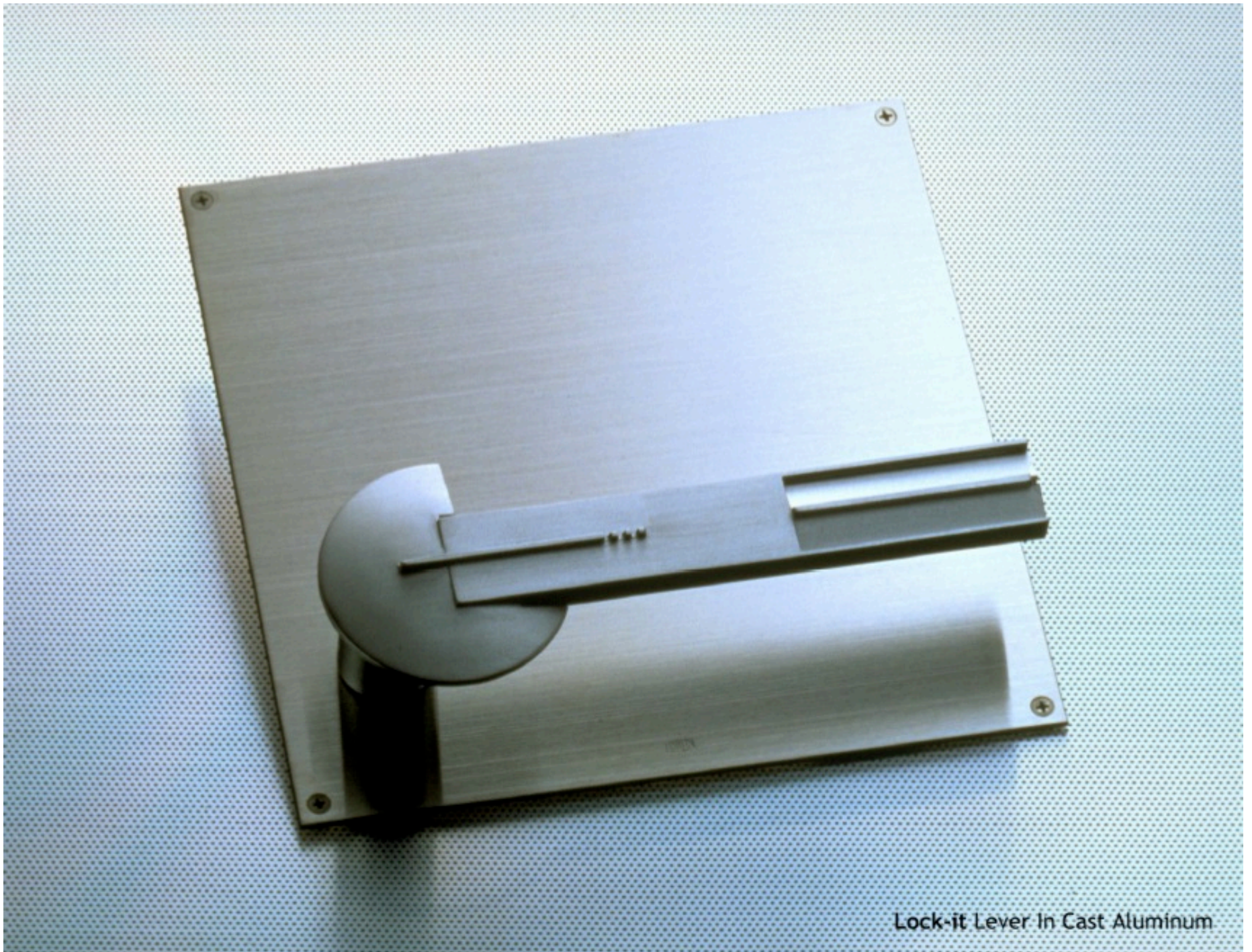

Lock-it Lever In Cast Aluminum

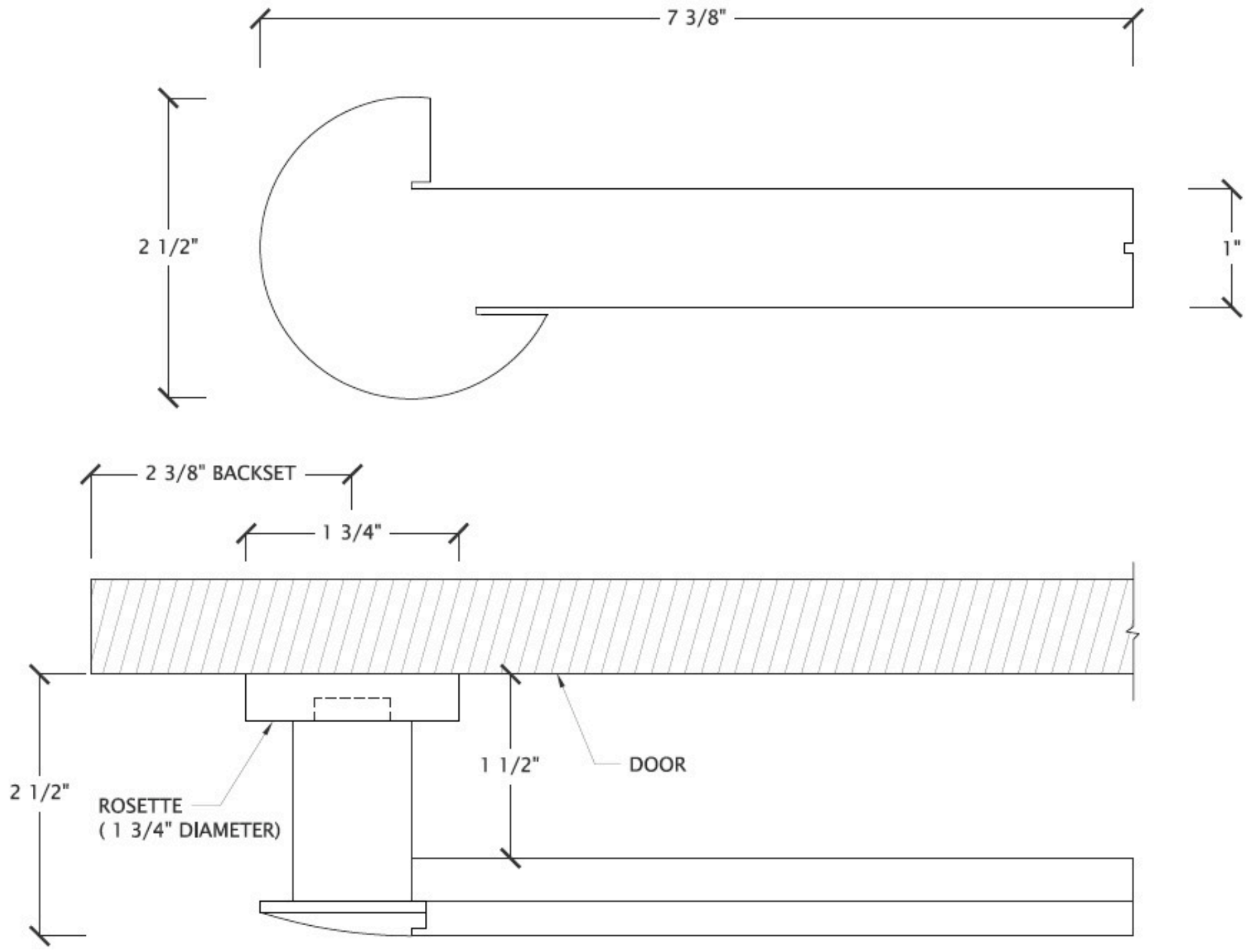

Chicago Tribune Magazine

MARCH 18, 2007 • SECTION 10

HOME DESIGN

WHAT'S HOT, WHAT'S NEXT

21

THINGS WE LOVE



GREAT ROOMS

ROOMS THAT BOTH KIDS
AND DADS CAN LIVE WITH

DOOR HANDLE WITH CARE

George Ranalli, architect, George
Ranalli Designs, New York, N.Y.

georgeranalli.com

Although I've designed furniture, I started designing hardware for the 21st Century so that my work could reach more than my clients. Hardware should follow the principles of ergonomics but

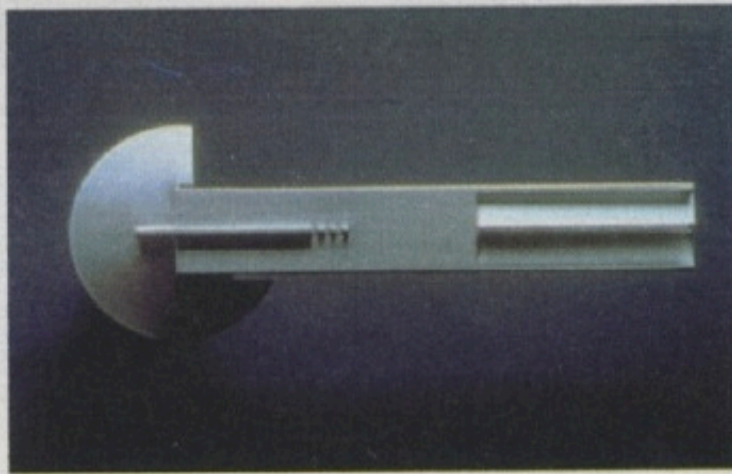

George Ranalli's Door Gems handle is easy to use and elegant.

also reflect good design. I want my handles, which I call Door Gems, to be warm and inviting to use—not cold. The Lock-it design, available through the museum shop at The Denver Art Museum or my Web site, is made of cast aluminum with a clear or lacquer finish and has a lever handle made of three pieces. You enjoy grasping it more than just holding a plain handle because of its tactile feeling.



1. Wind lever in satin nickel on square plate by Marital, circle 377. 2. Lock-it lever in cast aluminum by George Ramalli Designs, circle 378. 3. Wind Brick pull in satin chrome by Carl Martinez Hardware, circle 380. 4. Curved knob in stainless steel by Reveal Designs, circle 381. 5. Mercer lever in stainless steel by Reveal Designs, circle 382.



1. Elephant pulls in medium bronze by John Landrum Bryant. 2. Wave pulls in medium bronze by John Landrum Bryant, circle 383.



Charm Lever In Brass

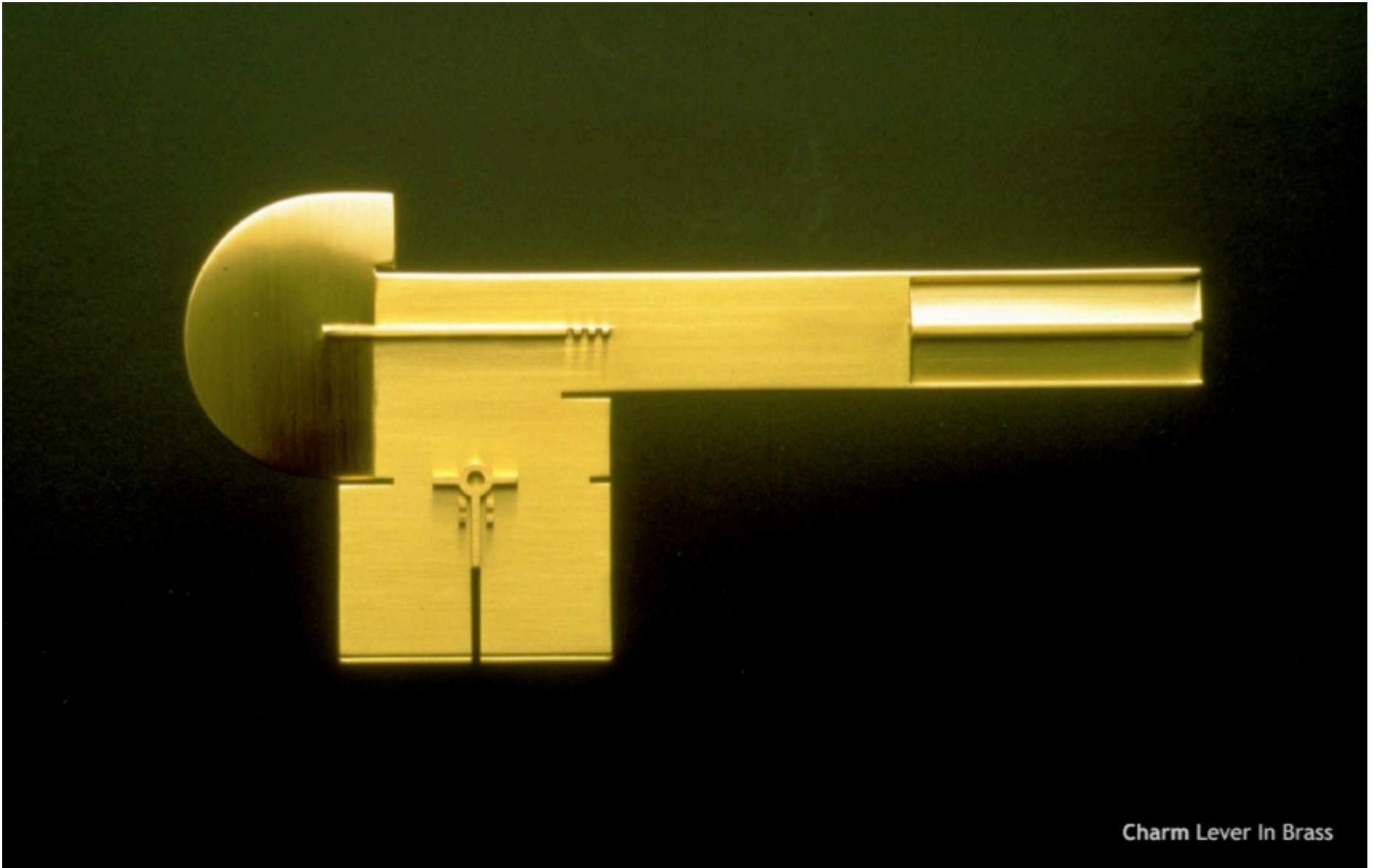

Charm Lever In Brass

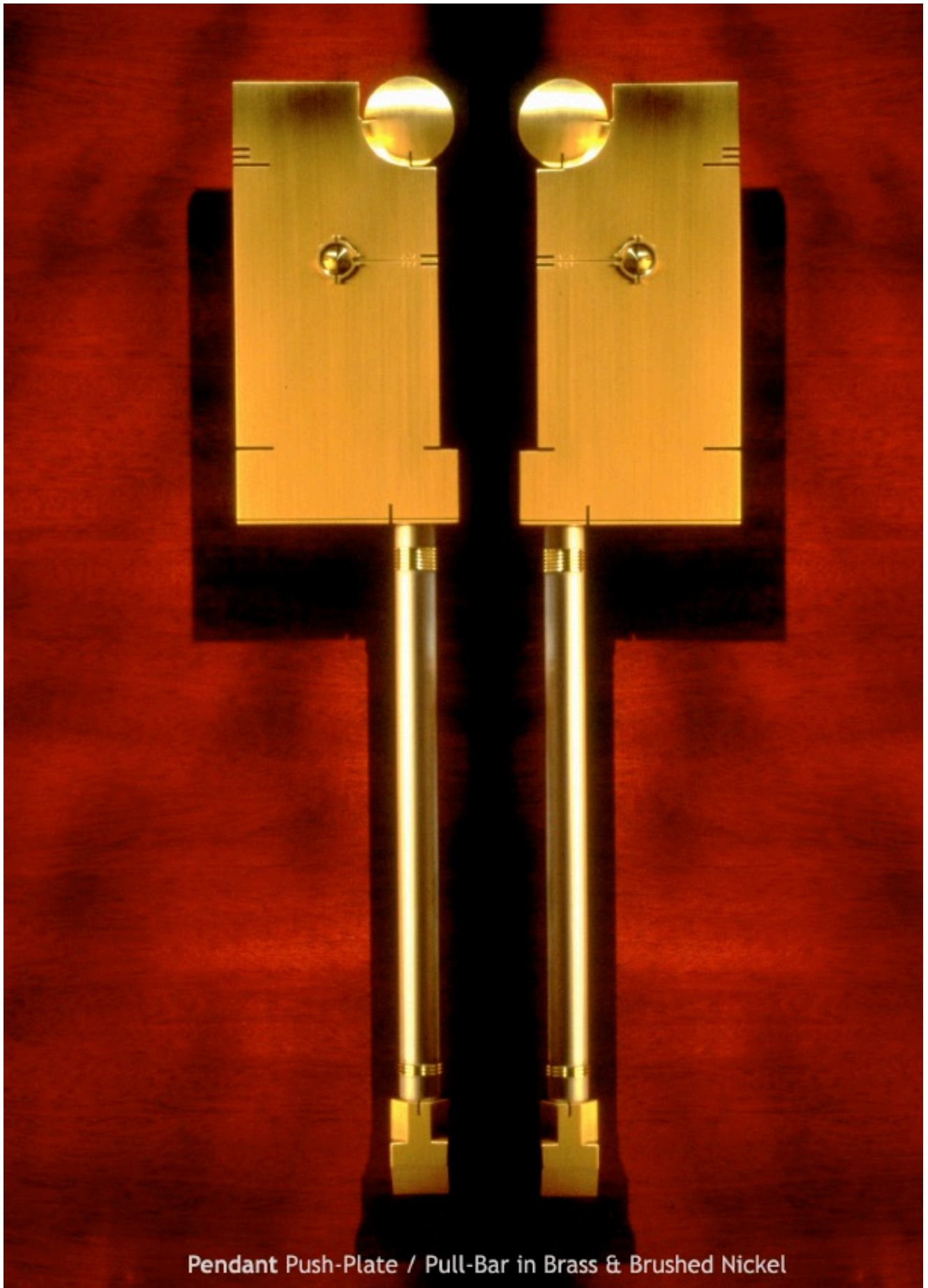

Pendant Push-Plate / Pull-Bar in Brass & Brushed Nickel

